



## G3441 GRIDDLE PLATE



### KEY FEATURES

- 18mm highly polished steel griddle plate
  - Provides consistent, even heat
- Temperature range of 140 - 300°C
  - A wide range of food items can be prepared
- Thermostatically controlled
  - Reduces energy consumption, improved operation
- Full height surround
  - Protects surrounding areas
- High performance burner
  - Maximum performance
- Piezo ignition
  - Efficient method of lighting, no electricity required
- Integral grease jug
  - Retains grease for quick and easy cleaning
- Supplied on adjustable feet
  - Variable working height
- Laser-etched control icons
  - permanent, indelible markings

### MODELS and ACCESSORIES

**G3441** - Polished steel griddle - smooth

- Stand with storage shelf with legs
- Stand with factory fitted, adjustable castors
- Fixed installation kit for stand
- Suiting kit

### INSTALLATION NOTES

Adequate ventilation must be provided to supply sufficient fresh air and to allow easy removal of any such products that may present a risk to health. Please consult current legislation for details that relate to specific locations.

Install unit on a level, fireproof surface in a well-lit position. If floor is made of a combustible material, local fire requirements must be checked to ensure compliance.

A clearance of 150mm should be observed between appliance and any combustible wall.





## G3441 GRIDDLE PLATE

### MODEL DIMENSIONS (in mm)

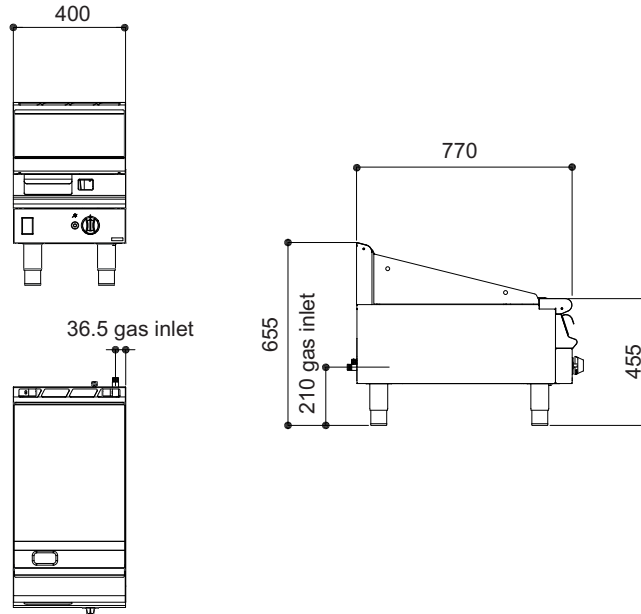

### SPECIFICATION DETAILS

	<b>G3441</b>
Total rating (natural and propane - kW - Nett)	5.3
Total rating (natural and propane - btu/hr - gross)	19,900
Inlet size (natural and propane)	1/2" BSP
Flow rate - natural (m <sup>3</sup> /hr)	0.52
Flow rate - propane (kg/hr)	0.41
Inlet pressure (natural and propane - mbar)	20 / 37
Operating pressure (natural and propane - mbar)	15 / 37
Burner rating (natural and propane - kW - Nett)	5.3
Burner rating (natural and propane - btu/hr - gross)	19,900
Cooking area (w x d - mm)	395 x 485
Number of burners	1
Height on bench legs (mm)	403
Height on optional stand (mm)	890
Weight (kg)	65
Packed weight (kg)	75